

JIS

JAPANESE
INDUSTRIAL
STANDARD

Translated and Published by
Japanese Standards Association

JIS G 3323 : 2012

(JISF)

**Hot-dip zinc-aluminium-magnesium
alloy-coated steel sheet and strip**

ICS 77.140.50

Reference number : JIS G 3323 : 2012 (E)

G 3323 : 2012

Date of Establishment: 2012-11-20

Date of Public Notice in Official Gazette: 2012-11-20

Investigated by: Japanese Industrial Standards Committee
Standards Board

Technical Committee on Iron and steel

JIS G 3323 : 2012, First English edition published in 2013-03

Translated and published by: Japanese Standards Association
4-1-24, Akasaka, Minato-ku, Tokyo, 107-8440 JAPAN

In the event of any doubts arising as to the contents,
the original JIS is to be the final authority.

© JSA 2013

All rights reserved. Unless otherwise specified, no part of this publication may be reproduced or utilized in any form or by any means, electronic or mechanical, including photocopying and microfilm, without permission in writing from the publisher.

Printed in Japan

NH/HN

Contents

	Page
1	Scope 1
2	Normative references 1
3	Grade, symbol and applicable nominal thickness 1
4	Chemical composition 3
5	Coating 4
5.1	Coating mass 4
5.2	Skin pass treatment 5
5.3	Coating adherence 5
6	Chemical treatment 6
7	Oiling 6
8	Mechanical properties 6
8.1	Applicable mechanical properties 6
8.2	Bendability 7
8.3	Tensile test characteristics 7
9	Dimensions and tolerances 9
9.1	Expression of dimensions 9
9.2	Standard size 10
9.3	Dimensional tolerances 10
10	Shape 13
10.1	Camber 13
10.2	Squareness 14
10.3	Flatness 15
11	Mass and tolerances thereof 16
11.1	Mass of sheet and corrugated sheet 16
11.2	Mass of coil 16
11.3	Calculation of mass 16
11.4	Tolerances on theoretical mass of sheet and corrugated sheet 17
12	Appearance 18
13	Tests 18
13.1	Chemical analysis 18
13.2	Coating test 18
13.3	Mechanical test 20
14	Inspection and re-inspection 21
14.1	Inspection 21

14.2	Re-inspection	21
15	Marking	21
16	Items to be confirmed at the time of order	23
17	Report	23
Annex A (normative)	Nominal thickness and coating mass symbol of sheet and coil for roofing and architectural siding	24
Annex B (normative)	Nominal thickness, coating mass symbol and standard size for corrugated sheet	25
Annex C (normative)	Off-line coating mass determination of hot-dip zinc-aluminium-magnesium alloy-coated steel sheet and strip by fluorescent X-ray method	26
Annex D (normative)	On-line coating mass determination of hot-dip zinc-aluminium-magnesium alloy-coated steel strips by fluorescent X-ray method	29

Foreword

This translation has been made based on the original Japanese Industrial Standard established by the Minister of Economy, Trade and Industry through deliberations at the Japanese Industrial Standards Committee according to the proposal for establishment of Japanese Industrial Standard submitted by the Japan Iron and Steel Federation (JISF) with the draft being attached, based on the provision of Article 12 Clause 1 of the Industrial Standardization Law.

Attention is drawn to the possibility that following this Standard may come under the use of the patent rights shown below.

Patent number	Title of invention	Registration date of establishment of patent right
No. 3149129	Hot dip Zn-Al-Mg coated steel sheet excellent in corrosion resistance and external surface appearance and its production	January 19, 2001
No. 3179401	Hot dip zinc-aluminium-magnesium plated steel sheet good in corrosion resistance and surface appearance and its production	April 13, 2001
No. 3179446	Plated steel sheet and coated steel sheet excellent in corrosion resistance and production of the same	April 13, 2001
No. 4064634	Hot-dip Zn-alloy galvanized steel sheet having excellent luster retention and its manufacturing method	January 11, 2008
No. 4171232	Hot dip plated steel having excellent surface smoothness	August 15, 2008
No. 4555491	Hot dip zinc-aluminium alloy plated steel sheet excellent in chemical conversion treatability and its production method	July 23, 2010

The relevant holders of the above-mentioned patent rights have indicated to the Japanese Industrial Standards Committee an intention of granting license to anyone under the nondiscriminatory and reasonable conditions, except to the other holders of the patent rights related to this Standard who will not grant their licenses under the same conditions.

It should be noted that following this Standard does not always refer to granting a free license.

Attention is drawn to the possibility that some parts of this Standard may conflict with patent rights as other than mentioned above. The Minister of Economy, Trade and Industry and Japanese Industrial Standards Committee are not responsible for identifying such patent rights.

The “patent rights” as mentioned here include a patent right, application for a patent after opening to the public or a utility model right.

Hot-dip zinc-aluminium-magnesium alloy-coated steel sheet and strip

1 Scope

This Japanese Industrial Standard specifies the steel sheet and strip (hereafter referred to as “sheet and coil”) and corrugated sheet manufactured by processing steel sheet into the shape and dimensions specified in **JIS G 3316**, which are coated so as to be equal thickness on both surfaces by a hot-dip zinc-aluminium-magnesium alloy coating process. The zinc-aluminium-magnesium alloy composition by mass fraction is normally 5.0 % to 13.0 % aluminium, 2.0 % to 4.0 % magnesium, 1.0 % other elements and the balance zinc.

2 Normative references

The following standards contain provisions which, through reference in this text, constitute provisions of this Standard. The most recent editions of the standards (including amendments) indicated below shall be applied.

JIS G 0320 *Standard test method for heat analysis of steel products*

JIS G 0404 *Steel and steel products — General technical delivery requirements*

JIS G 0415 *Steel and steel products — Inspection documents*

JIS G 0594 *Methods of accelerated cyclic corrosion resistance tests for anodic coatings with exposure to salt spray, dry and wet conditions*

JIS G 3316 *Shapes and dimensions of corrugated steel sheets*

JIS H 0401 *Test methods for hot dip galvanized coatings*

JIS H 8502 *Methods of corrosion resistance test for metallic coatings*

JIS K 0119 *General rules for X-ray fluorescence analysis*

JIS K 5600-7-9 *Testing methods for paints — Part 7 : Determination of resistance to cyclic corrosion conditions — Section 9 : Salt fog/dry/humidity*

JIS Z 2241 *Metallic materials — Tensile testing — Method of test at room temperature*

JIS Z 8401 *Guide to the rounding of numbers*

3 Grade, symbol and applicable nominal thickness ¹⁾

The class, symbol of grade and applicable nominal thickness shall be as follows.

Note ¹⁾ The nominal thickness refers to the thickness of the base metal before coating [see **9.1 a)**].

a) The sheets, corrugated sheets and coils shall be classified into 6 grades using hot

rolled steel sheets and strips (hereafter referred to as “hot-rolled base metal”) and into 11 grades using cold-rolled steel sheets and strips (hereafter referred to as “cold-rolled base metal”), and their grade symbols and applicable nominal thicknesses shall be as given in table 1 and table 2. Corrugated sheets shall be classified into 7 grades for commercial use, commercial use of full hard class and commercial use of high strength class in table 2, and their respective symbols shall be as those affixed with the symbol W, which stands for corrugated sheet, and the applicable symbol of shape of corrugation specified in **JIS G 3316** to the end of the symbol in table 2 (for sheet and coil used for roofing or architectural siding, after the symbol for roofing or architectural siding).

In addition, the applicable nominal thickness to corrugated sheets and the coating mass symbols shall be in accordance with Annex B.

- b) For sheets and coils used for roofing and architectural siding, the symbol R indicating roofing or the symbol A indicating architectural siding shall be suffixed to the symbol of grade in table 2. In this case, applicable nominal thickness and symbol of coating mass shall be in accordance with Annex A.

**Table 1 Grade symbol and applicable nominal thickness
[using hot-rolled base metal ^{a)}]**

Unit : mm

Symbol of grade	Applicable nominal thickness	Application
SGMHC	1.6 or over up to and incl. 9.0	For commercial use
SGMH340		For commercial use of high strength class
SGMH400		
SGMH440		
SGMH490		
SGMH540	1.6 or over up to and incl. 6.0 ^{b)}	
Notes ^{a)} When the hot rolled base metal is not especially designated for nominal thicknesses of 1.6 mm or over up to and including 3.2 mm, the cold rolled base metal satisfying the specification of hot rolled base metal may be used.		
^{b)} The nominal thickness of over 6.0 mm to and excluding 9.0 mm may be applied according to the agreement between the purchaser and the manufacturer.		

**Table 2 Grade symbol and applicable nominal thickness
(using cold-rolled base metal)**

Unit : mm

Symbol of grade	Applicable nominal thickness ^{a)}	Application
SGMCC	0.25 or over up to and incl. 3.2	For commercial use
SGMCH	0.20 or over up to and incl. 1.2	For commercial use of full hard
SGMCD1	0.40 or over up to and incl. 2.3	For drawing, Class 1
SGMCD2		For drawing, Class 2
SGMCD3	0.40 or over up to and incl. 2.3	For drawing, Class 3
SGMCD4		For drawing, Class 4 Non-aging property ^{b)}
SGMC340	0.25 or over up to and incl. 3.2	For commercial use of high strength class
SGMC400		
SGMC440		
SGMC490		
SGMC570	0.25 or over up to and incl. 2.0	
Notes ^{a)} The nominal thickness other than those in this table may be applied according to the agreement between the purchaser and the manufacturer.		
^{b)} The non-aging property means the property not to produce a stretcher strain at the time of processing.		

4 Chemical composition

For the chemical composition of the sheet, corrugated sheet and coil, the test shall be performed in accordance with 13.1 and the resultant heat analysis values shall be as given in table 3. Alloy elements other than those given in table 3 may be added as required.

Table 3 Chemical composition

Unit : %

Symbol of grade	C	Mn	P	S
SGMHC	0.15 max.	0.80 max.	0.05 max.	0.05 max.
SGMH340	0.25 max.	1.70 max.	0.20 max.	0.05 max.
SGMH400	0.25 max.	1.70 max.	0.20 max.	0.05 max.
SGMH440	0.25 max.	2.00 max.	0.20 max.	0.05 max.
SGMH490	0.30 max.	2.00 max.	0.20 max.	0.05 max.
SGMH540	0.30 max.	2.50 max.	0.20 max.	0.05 max.
SGMCC	0.15 max.	0.80 max.	0.05 max.	0.05 max.
SGMCH	0.18 max.	1.20 max.	0.08 max.	0.05 max.
SGMCD1	0.12 max.	0.60 max.	0.04 max.	0.04 max.
SGMCD2	0.10 max.	0.45 max.	0.03 max.	0.03 max.
SGMCD3	0.08 max.	0.45 max.	0.03 max.	0.03 max.
SGMCD4	0.06 max.	0.45 max.	0.03 max.	0.03 max.
SGMC340	0.25 max.	1.70 max.	0.20 max.	0.05 max.
SGMC400	0.25 max.	1.70 max.	0.20 max.	0.05 max.
SGMC440	0.25 max.	2.00 max.	0.20 max.	0.05 max.
SGMC490	0.30 max.	2.00 max.	0.20 max.	0.05 max.
SGMC570	0.30 max.	2.50 max.	0.20 max.	0.05 max.

5 Coating

5.1 Coating mass

5.1.1 Coating mass symbol

For coating, both surfaces shall be coated in equal thickness, and the coating mass symbol shall be as given in table 4.

5.1.2 Coating mass

For the coating mass, the test shall be performed in accordance with **13.2.2**, and the minimum coating mass shall be as follows. The maximum coating mass (total mass on both surfaces) may be agreed between the purchaser and the manufacturer.

- a) The coating mass on the sheet, corrugated sheet and coil shall be expressed by the total mass on both surfaces, and the triple-spot average minimum coating mass and the single-spot minimum coating mass shall be as given in table 4. Here, the specification of triple-spot average minimum coating mass shall apply to the average of the measured values of the coating mass of three test pieces cut from the sample, and the specification of the single-spot minimum coating mass shall apply to the smallest of the measured values of the coating masses of the three test pieces of which the average value is obtained. When the coating mass is determined according to the method in Annex D, the respective specifications shall apply to the average coating mass and the minimum coating mass obtained in **D.6.5**.
- b) The single-spot minimum coating mass on either surface on the sheet, corrugated sheet and coil should be 40 % or over of the single-spot minimum coating mass (total mass on both surfaces).

Table 4 Minimum coating mass (total mass of both surfaces)

Unit : g/m²

Nominal coating mass symbol	Triple-spot average minimum coating mass	Single-spot minimum coating mass
K06 ^{a)}	60	51
K08	80	68
K10	100	85
K12	120	102
K14	140	119
K18	180	153
K20	200	170
K22	220	187
K25	250	213
K27	275	234
K35 ^{a)}	350	298
K45 ^{a)}	450	383
To SGMCD1, SGMCD2, SGMCD3 and SGMCD4, coating mass of K35 and K45 shall not apply. Note ^{a)} Only applicable upon agreement between the purchaser and the manufacturer.		

5.2 Skin pass treatment

Skin-passing to obtain surface smoothness shall be in accordance with the designation by the purchaser. In this case, the symbol shall be S.

5.3 Coating adherence

For the coating adherence of the sheet, corrugated sheet and coil, when the test is performed in accordance with 13.2.3 under the bend test conditions given in table 5 or table 6, there shall be no flaking of the coating on the outside of the bent portion (within an area 7 mm or over from each side of the test piece). For corrugated sheets, this requirement shall apply to sheets before corrugation.

In addition, where there is no specification by the purchaser, the coating adherence may be evaluated in accordance with other evaluation test methods and acceptance criteria in place of the bend test for coating adherence at the discretion of the manufacturer. In this case, the criteria used shall be equivalent or superior to the coating adherence specified for bend test, as given in table 5 or table 6.

Table 5 Bend test condition 1

Symbol of grade	Bending angle	Internal spacing of bend (maximum number of sheets of nominal thickness)					
		Nominal thickness 1.6 mm or over to and excl. 3.0 mm			Nominal thickness 3.0 mm or over		
		Nominal coating mass symbol			Nominal coating mass symbol		
		K06 to K27	K35	K45	K06 to K27	K35	K45
SGMHC	180°	1	2	2	2	2	2
SGMH340		1	1	2	2	2	3
SGMH400		2	2	2	3	3	3
SGMH440		3	3	3	3	3	3
SGMH490 SGMH540							

Table 6 Bend test condition 2

Symbol of grade	Bending angle	Internal spacing of bend (maximum number of sheets of nominal thickness)								
		Nominal thickness Less than 1.6 mm			Nominal thickness 1.6 mm or over to and excl. 3.0 mm			Nominal thickness 3.0 mm or over		
		Nominal coating mass symbol			Nominal coating mass symbol			Nominal coating mass symbol		
		K06 to K27	K35	K45	K06 to K27	K35	K45	K06 to K27	K35	K45
SGMCC	180°	1	1	2	1	2	2	2	2	2
SGMCD1		1	—	—	1	—	—	—	—	—
SGMCD2 SGMCD3 SGMCD4		0 (Flat on itself)	—	—	0 (Flat on itself)	—	—	—	—	—
SGMC340		1	1	2	1	1	2	2	2	3
SGMC400		2	2	2	2	2	2	3	3	3
SGMC440		3	3	3	3	3	3	3	3	3
SGMC490										

6 Chemical treatment

The type and symbol of the chemical treatment to be given for sheet, corrugated sheet and coil shall be as given in table 7. Unless otherwise specified, the coating shall be subjected to the chromate treatment or chromate-free treatment.

Chemical treatments other than those in table 7 may be agreed upon between the purchaser and the manufacturer.

Table 7 Type and symbol of chemical treatment

Type of chemical treatment	Symbol
Chromate treatment	C
Chromate-free treatment ^{a)}	NC
Chromate-free of phosphate treatment ^{b)}	NP
Untreated	M
Notes ^{a)} Chromate-free treatment refers to the chemical treatment which does not contain the hexavalent chromium.	
^{b)} Chromate free of phosphate treatment refers to the chemical treatment which does not contain the hexavalent chromium carried out on the phosphate treatment.	

7 Oiling

The type and symbol of oiling for sheet, corrugated sheet and coil shall be as given in table 8. Unless otherwise specified, however, the coating shall be un-oiled.

Table 8 Type and symbol of oiling

Class of coating oil	Symbol
Oiled	O
Un-oiled	X

8 Mechanical properties

8.1 Applicable mechanical properties

Applicable mechanical properties for sheet, corrugated sheet and coil shall be as given in table 9. For corrugated sheets, the requirements shall apply to the sheets before corrugation.

Table 9 Applicable mechanical properties

Symbol of grade	Bendability	Tensile test characteristics ^{a)}
SGMHC	○	— ^{b)}
SGMH340	○	○
SGMH400	○	○
SGMH440	○	○
SGMH490	○	○
SGMH540	○	○
SGMCC	○ ^{c)}	— ^{b)}
SGMCH	— ^{d)}	— ^{b)}
SGMCD1	○	○
SGMCD2	○	○
SGMCD3	○	○
SGMCD4	○	○
SGMC340	○	○
SGMC400	○	○
SGMC440	○	○
SGMC490	○	○
SGMC570	— ^{d)}	○
Notes ^{a)} The tensile test shall not apply to those of nominal thickness under 0.25 mm. ^{b)} The tensile test characteristics shall not apply. ^{c)} If used for corrugated sheet, bendability shall not apply. ^{d)} Bendability shall not apply.		

8.2 Bendability

For the bendability of sheet, corrugated sheet and coil, when the test is performed in accordance with **13.3.2** under the bend test conditions given in table 5 and table 6, there shall be no cracking (visible to the naked eye) or fracture of the base metal on the outside of the bent portion (within an area 7 mm or over from each side of the test piece).

NOTE : For the performance of the bend test, see **13.3.2**.

8.3 Tensile test characteristics

For the tensile test characteristics of sheet, corrugated sheet and coil, when the test is performed in accordance with **13.3.3**, the result shall be as given in table 10 or table 11. The values given in table 10 or table 11 apply to the values obtained in shipping inspection ²⁾.

Note ²⁾ The sheet, corrugated sheet and coil can be subjected to increase of yield point or proof stress, or decrease of elongation due to aging effect.

Table 10 Tensile test characteristics 1

Symbol of grade	Yield point or proof stress N/mm ²	Tensile strength N/mm ²	Elongation %						Test piece and direction
			Thickness mm						
			1.6 or over to and excl. 2.0	2.0 or over to and excl. 2.5	2.5 or over to and excl. 3.2	3.2 or over to and excl. 4.0	4.0 or over up to and incl. 6.0	Over 6.0 up to and incl. 9.0	
SGMHC	(205 min.)	(270 min.)	—	—	—	—	—	—	No.5, rolling direction
SGMH340	245 min.	340 min.	20 min.	20 min.	20 min.	20 min.	20 min.	20 min.	No. 5, rolling direction or perpendicular to rolling direction
SGMH400	295 min. ^{a)}	400 min.	18 min.	18 min.	18 min.	18 min.	18 min.	18 min.	
SGMH440	335 min. ^{a)}	440 min.						16 min.	
SGMH490	365 min.	490 min.							
SGMH540	400 min.	540 min.							

Values in parentheses are shown for reference. However, they may be applied as specified values upon agreement between the purchaser and the manufacturer.

NOTE : 1 N/mm² = 1 MPa

Notes ^{a)} For the yield point or proof stress of SGMH400 and SGMH440, not less than 235 N/mm² and not less than 275 N/mm² may be applied respectively according to the agreement between the purchaser and the manufacturer. However, a symbol Y shall be marked at the end of the symbol of grade (in the case of roofing or architectural siding, before their symbols).

^{b)} Elongation shall be agreed between the purchaser and the manufacturer.

Table 11 Tensile test characteristic 2

Symbol of grade	Yield point or proof stress N/mm ²	Tensile strength N/mm ²	Elongation %						Test piece and direction
			Thickness mm						
			0.25 or over to and excl. 0.40	0.40 or over to and excl. 0.60	0.60 or over to and excl. 1.0	1.0 or over to and excl. 1.6	1.6 or over to and excl. 2.5	Over 2.5	
SGMCC	(205 min.)	(270 min.)	—	—	—	—	—	—	No.5, rolling direction
SGMCH	—	—	—	—	—	—	—		
SGMCD1	—	270 min.	—	30 min.	33 min.	36 min.	38 min.	—	
SGMCD2	—	270 min.	—	36 min.	38 min.	39 min.	40 min.	—	
SGMCD3	—	270 min.	—	38 min.	40 min.	41 min.	42 min.	—	
SGMCD4 ^{a)}	—	270 min.	—	40 min.	42 min.	43 min.	44 min.	—	
SGMC340	245 min.	340 min.	20 min.	20 min.	20 min.	20 min.	20 min.	20 min.	No. 5, rolling direction or perpendicular to rolling direction
SGMC400	295 min. ^{b)}	400 min.	18 min.	18 min.	18 min.	18 min.	18 min.	18 min.	
SGMC440	335 min. ^{b)}	440 min.	18 min.	18 min.	18 min.	18 min.	18 min.	18 min.	
SGMC490	365 min.	490 min.	16 min.	16 min.	16 min.	16 min.	16 min.	16 min.	
SGMC570	560 min.	570 min.	—	—	—	—	—	—	

Values in parentheses are shown for reference. However, they may be applied as specified values upon agreement between the purchaser and the manufacturer.

Note 1 Annealing is not applied to SGMCH, and usually the Rockwell hardness is not less than 85 HRBS or Vickers hardness is not less than 170 HV.

Note 2 1 N/mm² = 1 MPa

Note ^{a)} The sheet and coil of SGMCD4 shall be free from the occurrence of a stretcher strain marking at the time of processing for 6 months after manufacturing.

^{b)} For the yield point or proof stress of SGMC400 and SGMC440, not less than 235 N/mm² and not less than 275 N/mm² may be applied respectively according to the agreement between the purchaser and the manufacturer. However, a symbol Y shall be marked at the end of the symbol of grade (in the case of roofing or architectural siding, at the front of their symbols).

9 Dimensions and tolerances

9.1 Expression of dimensions

The dimensions of sheet, corrugated sheet and coil shall be expressed as follows :

- a) For the thickness of sheet, corrugated sheet and coil, the thickness of the base metal prior to coating shall be regarded as the nominal thickness and the thickness of the base metal after coating shall be regarded as the product thickness.

- b) The dimensions of sheet and corrugated sheet shall be expressed by nominal thickness, width and length in millimetres.
- c) The dimensions of coil shall be expressed by nominal thickness and width in millimetres. When the mass of coil is the theoretical mass, the length shall be expressed in metres.

9.2 Standard size

The standard size of sheet and coil shall be as follows. The standard nominal thickness of corrugated sheet, and the standard width and length before corrugation shall be in accordance with Annex B. Further, the standard length and standard finished width of corrugated sheet shall be in accordance with **JIS G 3316**.

- a) **Standard nominal thickness** The standard nominal thickness of sheet and coil shall be as given in table 12.

Table 12 Standard nominal thickness

Unit : mm

Standard nominal thickness												
0.25	0.27	0.30	0.35	0.40	0.50	0.60	0.70	0.80	0.90	1.0	1.2	1.4
1.6	1.8	2.0	2.3	2.8	3.2	3.6	4.0	4.5	5.0	5.6	6.0	7.0
Besides this table, 0.65 mm, 0.75 mm and 8.25 mm may be regarded as standard nominal thickness according to the agreement between the purchaser and the manufacturer.												

- b) **Standard width and standard length of sheet** The standard width of sheet and coil, and the standard length of sheet shall be as given in table 13.

Table 13 Standard width and standard length of sheet

Unit : mm

Standard width	Standard length of sheet						
762	1 829	2 134	2 438	2 743	3 048	3 353	3 658
914	1 829	2 134	2 438	2 743	3 048	3 353	3 658
1 000	2 000						
1 219	2 438	3 048	3 658				
1 524	3 048						
1 829	3 658						
For coil, other than the above, 610 mm may be applied as the standard width.							

9.3 Dimensional tolerances

9.3.1 Tolerances on product thickness

Tolerances on the product thickness of sheet, corrugated sheet and coil as follows :

- a) Tolerances on the product thickness shall apply to the value of the nominal thickness expressed to three decimal places, to which the equivalent coating thickness given in table 14 is added, and then rounded to two decimal places in accordance with Rule A of **JIS Z 8401**.

- b) Tolerances on the product thickness shall be as given in table 15, table 16 or table 17.
- c) The product thickness shall be measured at any point 25 mm or over inside from the side edges (the ends in the width direction).
- d) These tolerances shall not apply to the irregular portions such as welds in a coil.

Table 14 Equivalent coating thickness

Unit : mm

Classifica- tion	Nominal coating mass symbol												Informative Mass fraction of aluminium coating
	K06	K08	K10	K12	K14	K18	K20	K22	K25	K27	K35	K45	
1	0.015	0.020	0.025	0.031	0.034	0.041	0.048	0.051	0.059	0.064	0.076	0.094	5.0 % or over up to and incl. 9.0 %
2	0.016	0.021	0.027	0.033	0.036	0.044	0.051	0.054	0.062	0.068	0.082	0.101	Over 9.0 % up to and incl. 13.0 %

Table 15 Tolerances on product thickness (applicable to SGMHC)

Unit : mm

Nominal thickness	Width			
	Under 1 200	1 200 or over to and excl. 1 500	1 500 or over to and excl. 1 800	1 800 or over to and excl. 2 000
1.60 or over to and excl. 2.00	±0.17	±0.18	±0.19	±0.22
2.00 or over to and excl. 2.50	±0.18	±0.20	±0.22	±0.26
2.50 or over to and excl. 3.15	±0.20	±0.22	±0.25	—
3.15 or over to and excl. 4.00	±0.22	±0.24	±0.27	—
4.00 or over to and excl. 5.00	±0.25	±0.27	±0.29	—
5.00 or over to and excl. 6.00	±0.27	±0.29	—	—
6.00 or over to and excl. 8.00	±0.30	±0.31	—	—
8.00 or over up to and incl. 9.00	±0.33	—	—	—

Table 16 Tolerances on product thickness (applicable to SGMH340, SGMH400, SGMH440, SGMH490 and SGMH540)

Unit : mm

Nominal thickness	Width	
	Under 1 600	1 600 or over to and excl. 2 000
1.60 or over to and excl. 2.00	±0.20	±0.24
2.00 or over to and excl. 2.50	±0.21	±0.26
2.50 or over to and excl. 3.15	±0.23	±0.30
3.15 or over to and excl. 4.00	±0.25	—
4.00 or over to and excl. 5.00	±0.46	—
5.00 or over to and excl. 6.30	±0.51	—
6.30 or over up to and incl. 9.00	±0.56	—

Table 17 Tolerances on product thickness (applicable to SGMCC, SGMCH, SGMCD1 to SGMCD4 and SGMC340 to SGMC570)

Unit : mm

Nominal thickness	Width				
	Under 630	630 or over to and excl. 1 000	1 000 or over to and excl. 1 250	1 250 or over to and excl. 1 600	1 600 or over
Under 0.25 ^{a)}	(±0.04)	(±0.04)	(±0.04)	—	—
0.25 or over to and excl. 0.40	±0.05	±0.05	±0.05	±0.06	—
0.40 or over to and excl. 0.60	±0.06	±0.06	±0.06	±0.07	±0.08
0.60 or over to and excl. 0.80	±0.07	±0.07	±0.07	±0.07	±0.08
0.80 or over to and excl. 1.00	±0.07	±0.07	±0.08	±0.09	±0.10
1.00 or over to and excl. 1.25	±0.08	±0.08	±0.09	±0.10	±0.12
1.25 or over to and excl. 1.60	±0.09	±0.10	±0.11	±0.12	±0.14
1.60 or over to and excl. 2.00	±0.11	±0.12	±0.13	±0.14	±0.16
2.00 or over to and excl. 2.50	±0.13	±0.14	±0.15	±0.16	±0.18
2.50 or over to and excl. 3.15	±0.15	±0.16	±0.17	±0.18	±0.21
3.15 or over up to and incl. 3.20	±0.17	±0.18	±0.20	±0.21	—
Over 3.20 ^{a)}	(±0.17)	(±0.18)	(±0.20)	(±0.21)	—

The tolerances in parentheses are shown for reference. However, they may be applied as specification values upon agreement between the purchaser and the manufacturer.

Note ^{a)} Nominal thickness to be applied upon agreement between the purchaser and the manufacturer.

9.3.2 Tolerances on width

Tolerances on the width of sheet and coil shall be as given in table 18, table 19 and table 20. Table 18 shall apply to regularly cut sheet and coil, table 19 shall apply to those subjected to re-cutting and precision cutting and table 20 apply to those subjected to slitting. Width shall be measured at a normal portion in a coil and at arbitrary position of sheet. For the width tolerances in table 19, the whole specified tolerance range may be moved to the negative side upon agreement between the purchaser and the manufacturer. However, the upper limit of agreed tolerance shall not be below zero.

Tolerances on the finished width of corrugated sheet shall be in accordance with **JIS G 3316**.

Table 18 Tolerance on width 1

Unit : mm

Width	Symbol of applicable grade		
	SGMHC, SGMH340, SGMH400, SGMH440, SGMH490, SGMH540		SGMCC, SGMCH, SGMCD1 to SGMCD4, SGMC340 to SGMC570
	Tolerance A ^{a)}	Tolerance B ^{a)}	
1 500 or under	+25 0	+10 0	+7 0
Over 1 500			+10 0

Note ^{a)} Generally, tolerance A applies to mill edge, and tolerance B applies to cut edge.

Table 19 Tolerance on width 2

Unit : mm

Width	
Under 1 250	1 250 or more
+3	+4
0	0

Table 20 Tolerance on width 3

Unit : mm

Nominal thickness	Width			
	Under 160	160 or over to and excl. 250	250 or over to and excl. 400	400 or over to and excl. 630
Under 0.25 ^{a)}	(±0.15)	(±0.20)	(±0.25)	(±0.30)
0.25 or over to and excl. 0.60	±0.15	±0.20	±0.25	±0.30
0.60 or over to and excl. 1.00	±0.20	±0.25	±0.25	±0.30
1.00 or over to and excl. 1.60	±0.20	±0.30	±0.30	±0.40
1.60 or over to and excl. 2.50	±0.25	±0.35	±0.40	±0.50
2.50 or over to and excl. 3.20	±0.30	±0.40	±0.45	±0.50
3.20 or over	±0.50	±0.50	±0.50	±0.50

Tolerances in parentheses are shown for reference. However, they may be applied as specification values upon agreement between the purchaser and the manufacturer.
 Note ^{a)} Nominal thicknesses to be applied upon agreement between the purchaser and the manufacturer.

9.3.3 Tolerances on length

Tolerances on the length of sheet and corrugated sheet shall be as given in table 21. The length shall be measured at an arbitrary position of the sheet or corrugated sheet.

Table 21 Tolerance on length

Unit : mm

Tolerance on length
+15
0

10 Shape

10.1 Camber

The application of camber for sheet, corrugated sheet and coil shall be as shown in figure 1. For corrugated sheet, the requirement shall apply to sheet before corrugation. The maximum camber of sheet, corrugated sheet and coil shall be as given in table 22 or table 23. However, the camber shall not apply to the irregular portions in a coil. The measurement of camber may be omitted ³⁾, unless particularly specified by the purchaser.

Note ³⁾ The measurement of camber may be omitted by the judgement of the manufacturer, but the camber requirement still has to be satisfied.

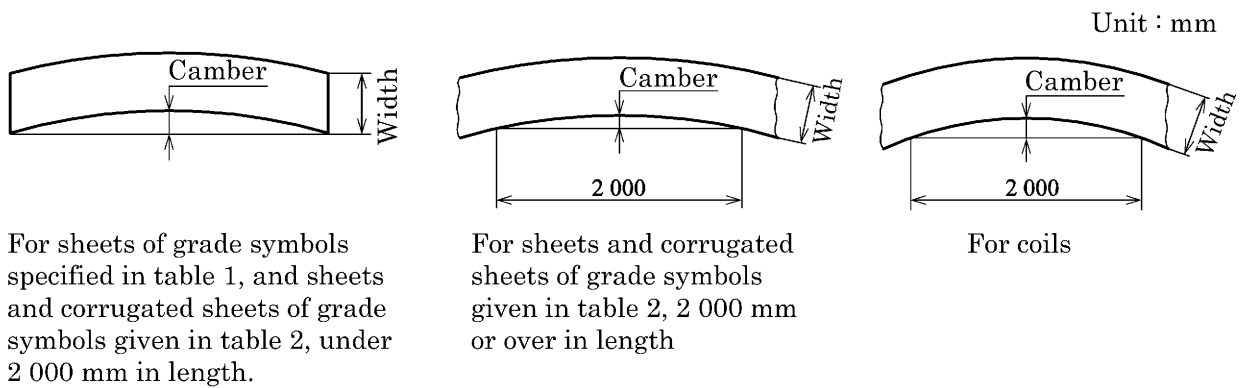

Figure 1 Application of camber

Table 22 Maximum value of camber (applicable to SGMHC, SGMH340, SGMH400, SGMH440, SGMH490 and SGMH540)

Unit : mm

Width	Sheet			Coil
	Length			
	Under 2 500	2 500 or over to and excl. 4 000	4 000 or over	
Under 630	5	8	12	5 per length of 2 000
630 or over to and excl. 1 000	4	6	10	
1 000 or over	3	5	8	

Table 23 Maximum value of camber (applicable to SGMCC, SGMCH, SGMCD1 to SGMCD4 and SGMCD340 to SGMCD570)

Unit : mm

Width	Sheet and corrugated plate		Coil
	Length		
	Under 2 000	2 000 or more	
Under 630	4	4 per length of 2 000	
630 or more	2	2 per length of 2 000	

10.2 Squareness

The squareness of sheet and corrugated sheet shall be in accordance with either of the following. For corrugated sheet, the requirements apply to the sheet before corrugation.

In cases of doubts, method in a) shall be applied.

- a) **Method using a vertical line** The squareness of a sheet or a corrugated sheet shall be expressed, as shown in figure 2, by the ratio (A/B) between the distance (A) from the vertical line drawn from one corner of a sheet to the opposite corner and the length of the vertical line (B). This ratio shall not exceed 1.0 %.

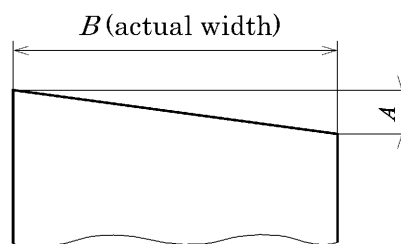

Figure 2 Squareness of sheet and corrugated sheet (method using a vertical line)

- b) **Method using diagonal lines** The absolute value of the difference $1/2 (|X_1 - X_2|/2)$ between lengths of the two diagonal lines (X_1 and X_2 in figure 3) of a sheet or corrugated sheet shall be obtained. This difference shall not exceed 0.7 % of actual width W of the sheet or corrugated sheet.

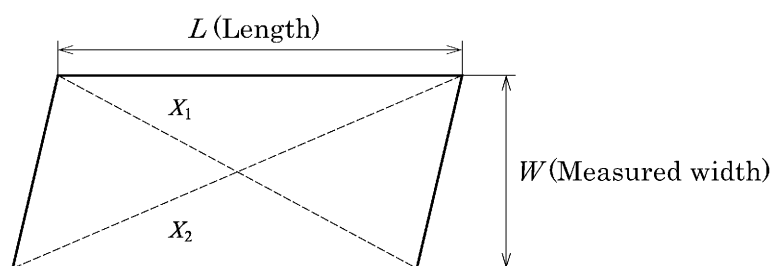

Figure 3 Squareness of sheet and corrugated sheet (method using diagonal lines)

10.3 Flatness

The flatness of sheet and coil shall be as follows :

a) **Flatness of sheet**

The flatness of sheet shall be as given in table 24 or table 25. The flatness shall be measured with a sheet lying on a flat surface, and the value of flatness shall be obtained by subtracting the product thickness from the maximum strain. The value thus obtained shall apply to the upper surface of the sheet.

Table 24 Flatness (applicable to SGMHC, SGMH340, SGMH400, SGMH440, SGMH490 and SGMH540)

Unit : mm

Nominal thickness	Width		
	Under 1 250	1 250 or over to and excl. 1 600	1 600 or over
1.60 or over to and excl. 3.15	16 or under	18 or under	20 or under
3.15 or over to and excl. 4.00	16 or under		
4.00 or over to and excl. 6.00	14 or under		
6.00 or over up to and incl. 9.00	13 or under		

Table 25 Flatness (applicable to SGMCC, SGMCH, SGMCD1 to SGMCD4 and SGMC340 to SGMC570)

Unit : mm

Width	Type of strain ^{a)}		
	Bow, wave	Edge wave	Centre buckle
Under 1 000	12 max.	8 max.	6 max.
1 000 or over to and excl. 1 250	15 max.	9 max.	8 max.
1 250 or over to and excl. 1 600	15 max.	11 max.	8 max.
1 600 or more	20 max.	13 max.	9 max.
Note ^{a)} The types of strain, of different shapes and position of occurrence, are as follows : Bow : overall warp of a steel sheet, which can be in the rolling direction or normal to the rolling direction. Wave : waviness in the rolling direction of a steel sheet. Edge wave : corrugation at edges (the ends in the width direction) of a steel sheet. Centre buckle : corrugation at the central part of a steel sheet.			

b) Flatness of coil

The flatness of coil shall be in accordance with table 24 or table 25, except for the camber requirement which is not applicable to coil. Further, the flatness requirements of coil shall not apply to irregular portions of the coil. The flatness of coil shall be inspected on an inspection table placed in the production line of coil. If the report of measured values is required, the measurement method or other details shall be agreed between the purchaser and the manufacturer.

The measurement of flatness of coil may be omitted ⁴⁾.

Note ⁴⁾ The measurement of flatness may be omitted at the discretion of the manufacturer, but the flatness requirement values still has to be satisfied.

11 Mass and tolerances thereof

11.1 Mass of sheet and corrugated sheet

The mass of sheet and corrugated sheet shall usually be given in the theoretical mass in kilogrammes.

11.2 Mass of coil

The mass of coil shall be given either in the actual mass or theoretical mass in kilogrammes.

11.3 Calculation of mass

The mass of sheet, corrugated sheet and coil shall be calculated according to table 26.

Table 26 Calculation of mass

Calculation order		Calculation method	Rounding ^{a)}
Basic mass of base metal kg/(mm · m ²)		7.85 ^{b)}	—
Unit mass of base metal kg/m ²		Basic mass of base metal [kg/(mm · m ²)] × nominal thickness (mm)	Rounded off to 4 significant figures.
Unit mass after coating kg/m ²		Unit mass of base metal (kg/ m ²) + coat- ing mass constant (kg/ m ²) ^{c)}	Rounded off to 4 significant figures.
Sheet and corrugated sheet	Area of sheet and corru- gated sheet ^{d)} m ²	Width (mm) × length (mm) × 10 ⁻⁶	Rounded off to 4 significant figures.
	Mass of a single sheet kg	Unit mass after coating (kg/m ²) × area (m ²)	Rounded off to 3 significant figures.
	Mass of a single bundle ^{e)} kg	Mass of a single sheet (kg) × number of sheets of the same dimensions in one bundle	Rounded to an integer in kilo- grammes
	Total mass kg	Total mass of each bundle (kg)	Integer in kilogrammes.
Coil	Unit mass of coil kg/m	Unit mass after coating (kg/ m ²) × width (mm) × 10 ⁻³	Rounded to 3 significant figures.
	Mass of single coil kg	Unit mass of coil (kg/m) × length (m)	Rounded to an integer in kilogrammes.
	Total mass kg	Total mass of each coil (kg)	Integer in kilogrammes.
Notes ^{a)} The values shall be rounded according to Rule A of JIS Z 8401 . ^{b)} The basic mass of the base metal per thickness 1 mm × area 1 m ² . ^{c)} Coating mass constant shall be in accordance with table 27. ^{d)} The width used for calculation of area of corrugated sheet shall be the dimension be- fore corrugation. ^{e)} When the mass of bundle is specified, the number of sheets in one bundle shall be cal- culated by dividing the specified mass of a bundle of sheets grouped by the shape, di- mensions and coating mass by the mass of one sheet, and rounding the result to an integer.			

Table 27 Coating mass constant used for calculation of mass

		Unit : kg/m ²										
Coating mass symbol	K06	K08	K10	K12	K14	K18	K20	K22	K25	K27	K35	K45
Coating mass constant	0.090	0.120	0.150	0.183	0.203	0.244	0.285	0.305	0.350	0.381	0.458	0.565

11.4 Tolerance on theoretical mass of sheet and corrugated sheet

Tolerances on the theoretical mass of sheet and corrugated sheet, which are expressed as the percentage obtained by dividing the difference between the theoretical mass obtained by 11.3 and the actual mass by the theoretical mass, shall be as given in table 28.

Table 28 Tolerance on mass

Theoretical mass of a group ^{a)} kg	Tolerance %
Under 600	±10
600 or over to and excl. 2 000	±7.5
2 000 or more	±5
Note ^{a)} A group of sheets of the same material, same shape, same dimension and the same coating mass, which shall be the basis of calculation.	

12 Appearance

The sheet, corrugated sheet and coil shall be free from defects which may be detrimental to practical use. The coils can include some abnormal portions or welds, since it is generally difficult to inspect the overall coils for defects and there is no chance to remove defective portions. In the case where the treatment of abnormal portions of the coils is necessary, the method of treatment may be agreed between the purchaser and the manufacturer.

Unless otherwise specified, surface defects shall be applied to one side surface ⁵⁾ of the sheet, corrugated sheet and coil.

NOTE : The defects can be pores, lamination, or surface flaws.

Note ⁵⁾ One side surface usually refers to the upper side surface in packaging, in the case of sheet and corrugated sheet, and the outside surface of coil, in the case of coil.

13 Tests

13.1 Chemical analysis

13.1.1 General matters of chemical analysis and sampling method

The chemical composition of the sheet, corrugated sheet and coil shall be determined by the heat analysis and the general matters of chemical analysis and sampling method shall be in accordance with clause 8 of JIS G 0404.

13.1.2 Analytical method

The analytical method shall be in accordance with JIS G 0320.

13.2 Coating test

13.2.1 Sampling method

One sample shall be taken from every 50 t or fraction thereof of products of the same dimension and coating mass.

For the corrugated sheet, the sample shall be taken from the flat sheet before corrugation.

13.2.2 Coating mass test

The coating mass test shall be as follows :

- a) **Test method** The coating mass shall be measured on both sides, and the test method shall be in accordance with any one of 5.2 of JIS H 0401, Annex C or Annex D. In cases of doubts, 5.2 of JIS H 0401 shall be applied.

If the method in Annex D is applied, the measurement shall be on every 50 t of products of the same dimension and the same coating mass, or fraction thereof.

- b) **Sampling position, size and number of test pieces** The sampling position and size and number of test pieces shall be as follows :
- 1) For the method in 5.2 of JIS H 0401, the sampling position and number of test pieces shall be in accordance with C.5.2. The size of the test piece shall be at least 1 200 mm².
 - 2) For the method in Annex C, the sampling position, and size and number of test pieces shall be in accordance with C.5.
 - 3) For the method in Annex D, the coil shall be directly measured without taking test pieces.

13.2.3 Coating adherence test

The coating adherence bend test shall be as follows.

- a) **Sampling position and size of test pieces** The test pieces shall be taken from any position of the sample, such that they have a width of 75 mm to 125 mm and an appropriate length of approximately twice the width. One test piece shall be taken in parallel to the rolling direction of the base metal, unless otherwise specified.
- b) **Bending of the test pieces** The test pieces shall be bent as shown in figure 4 by means of a manual vice, with the number of plates specified in table 5 or table 6 inserted to secure the required internal spacing, through 180° in the longitudinal direction of the test piece. Where the use of a vice is not possible, other suitable method may be used.

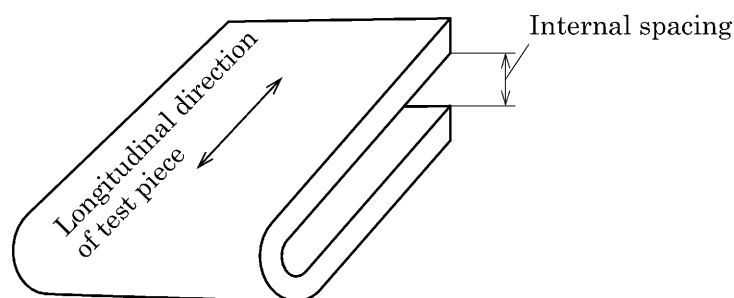

Figure 4 Direction of bend test

13.2.4 Corrosion resistance test of coating

The corrosion resistance test of coating shall be performed by any one of the methods in clause 8 of JIS H 8502, Annex 1 of JIS K 5600-7-9 or JIS G 0594.

This test shall be performed in accordance with the agreement between the purchaser and the manufacturer, and the evaluation criteria (setting of reference value and characteristics value) may be as agreed between the purchaser and the manufacturer.

NOTE : In corrosion test of coating, generally, the test results are reported without setting the criteria.

13.3 Mechanical test

13.3.1 General matters

The general matters of the mechanical test shall be in accordance with clause 7 and clause 9 of JIS G 0404. In this case, the sampling method shall be Group A in 7.6 of JIS G 0404, and in the case of corrugated sheet, the sample shall be taken from the sheet before corrugation. The number and the sampling position of the test pieces shall be as follows :

- a) **Number of test pieces** One bend test piece and one tensile test piece shall be taken from every 50 t of the products of the same grade, thickness and coating mass, or fraction thereof.
- b) **Sampling position of test piece** The test pieces shall be taken such that their centre is at or in proximity to 1/4 of the width.

13.3.2 Bend test

The bend test shall be in accordance with 13.2.3.

The bend test may be omitted ⁶⁾, unless particularly specified by the purchaser.

Note ⁶⁾ The test may be omitted at the discretion of the manufacturer, but the bendability requirement still has to be satisfied.

13.3.3 Tensile test

The tensile test shall be as follows :

- a) **Test piece** The test piece shall be a No. 5 test piece of JIS Z 2241, and one shall be cut from the sample in the direction as given in table 10 and table 11.
- b) **Test method** The test method shall be in accordance with JIS Z 2241.
- c) **Thickness used for calculation of yield point or proof stress, and tensile strength**
The thickness used for calculation of yield point or proof stress, and tensile strength shall be in accordance with any of the following.
 - actual thickness after removing the coating layer,
 - thickness obtained by subtracting the equivalent coating thickness from the actual thickness including the coating layer,
 - thickness obtained by subtracting the converted coating thickness ⁷⁾ of the actual coating mass from the actual thickness including the coating layer.

Note ⁷⁾ The converted coating thickness is obtained by dividing the actual coat-

ing mass by the coating density (6.0 g/cm³ for division 1 and 5.6 g/cm³ for division 2 in table 14), and calculating to three decimal places in millimetres.

14 Inspection and re-inspection

14.1 Inspection

The inspection shall be as follows:

- a) Chemical composition shall comply with clause 4.
- b) Coating mass shall comply with 5.1.
- c) Coating adherence shall comply with 5.3.
- d) Mechanical properties shall comply with clause 8.
- e) Dimensions shall comply with clause 9.
- f) Shape shall comply with clause 10.
- g) Mass shall comply with clause 11.
- h) Appearance shall comply with clause 12.

14.2 Re-inspection

For the sheet, corrugated sheet and coil having failed to meet the requirements of the coating mass test, the coating adherence test, the bend test or the tensile test, re-tests may be performed for acceptance in accordance with 9.8 of JIS G 0404.

15 Marking

For each package or bundle of sheets, corrugated sheets and coils that have passed the inspection, the following items shall be legibly marked by a suitable means.

For sheets and corrugated sheets, marking may be given on each sheet if agreed between the purchaser and the manufacturer.

- a) Grade symbol. In the case of applying Note ^{a)} of table 10 and Note ^{b)} of table 11, Y shall be marked at the end of the symbol of grade.
- b) Symbol for roofing, symbol for architectural siding and/or symbol for the corrugated sheet (including the shape symbol for corrugated sheet) : These symbols shall be marked after the grade symbol.
- c) Symbol for skin-pass treatment and/or symbol for chemical treatment, symbol for oiling : These symbols shall be marked when specified by the purchaser.
- d) Nominal coating mass symbol
- e) Dimensions (See 9.1. Only the nominal thickness in the case of one sheet.)
- f) Identification number of product
- g) Number of sheets or mass (this may be omitted in the case of one sheet.)

h) Manufacturer's name or its identifying brand

Marking shall be as shown in the following examples :

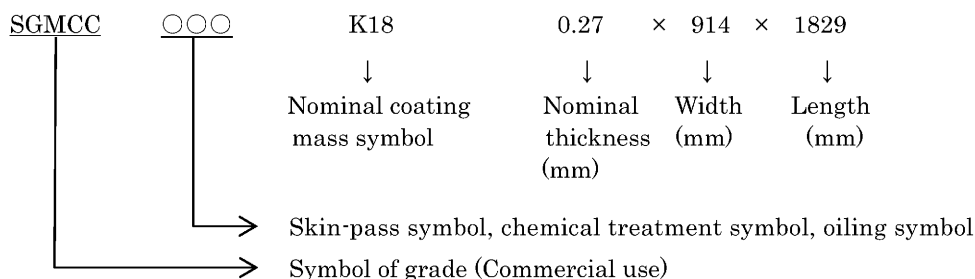
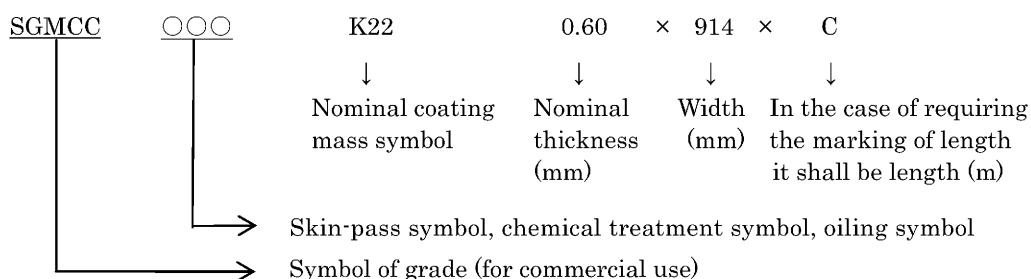
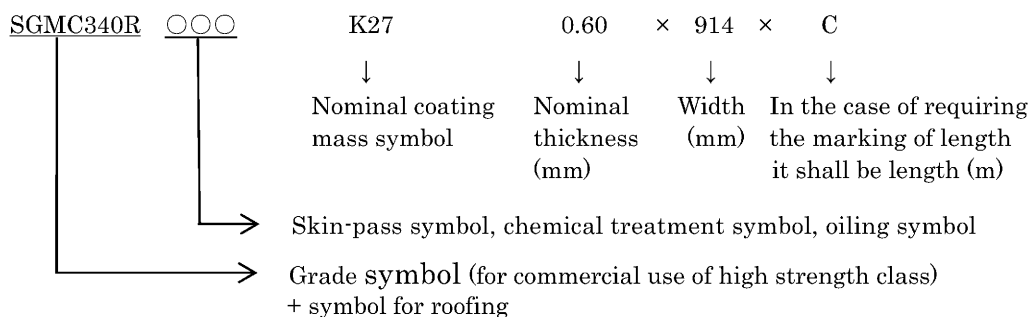
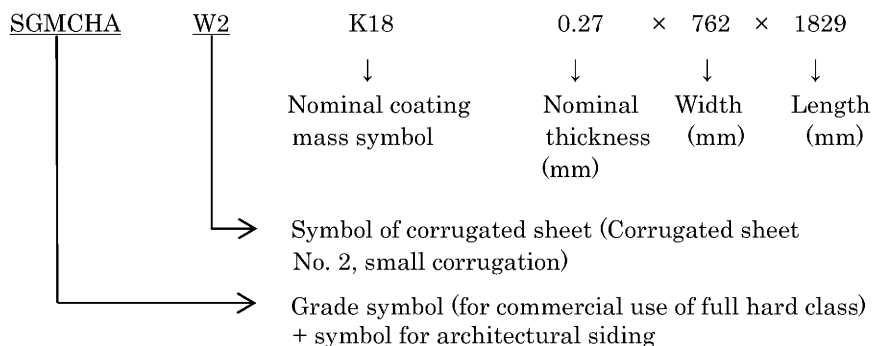
Example 1 Sheet**Example 2 Coils****Example 3 Coils for roofing****Example 4 Corrugated sheet using sheet for commercial use of full hard class**

16 Items to be confirmed at the time of order

The purchaser and the manufacturer should include the following information in an inquiry sheet and an order sheet in order to specify the requirements according to this Standard properly.

- a) Grade symbol (table 1 and table 2)
- b) Dimensions (For standard nominal thickness, standard width and standard length, table 12 and table 13. For corrugated sheet, table B.2 and **JIS G 3316**.)
- c) Skin-pass
- d) Nominal coating mass symbol (table 4)
- e) Symbol for chemical treatment (table 7)
- f) Symbol for oiling (table 8)
- g) Maximum mass and minimum mass of one bundle or one coil of product
- h) Total mass ordered
- i) Tolerance on width (table 18, table 19 and table 20)
- j) Internal diameter and external diameter, in the case of a coil
- k) Application, processing method, etc. when possible

17 Report

The manufacturer shall submit the inspection document to the purchaser, if required by the purchaser. The report shall be in accordance with clause 13 of **JIS G 0404**. However, carbon, phosphorus and sulfur among chemical components may be reported to three decimal places. The division in table 14 applied to the equivalent coating thickness shall be reported. Unless otherwise specified, the type of the inspection document to be submitted shall be the standard designation 2.3 or 3.1B in table 1 of **JIS G 0415**.

Annex A (normative)

Nominal thickness and coating mass symbol of sheet and coil for roofing and architectural siding

A.1 Scope

This Annex specifies the nominal thickness and the coating mass symbol applicable to sheet, corrugated sheet and coil (using cold-rolled base metal) for roofing and architectural siding.

A.2 Applicable nominal thickness and coating mass symbol

The nominal thickness and the coating mass symbol applicable to sheet, corrugated sheet and coil for roofing and architectural siding shall be as given in table A.1.

**Table A.1 Applicable nominal thickness and coating mass symbol
(using cold-rolled base metal)**

Application	Applicable nominal thickness mm	Coating mass symbol ^{a)}
For roofing	0.35 or over up to and incl. 1.0	K14, K18, K20, K22, K25, K27
	Over 1.0	K18, K20, K22, K25, K27
For architectural siding	0.27 or over up to and incl. 0.50	K08, K10, K12, K14, K18, K20, K22, K25, K27
	Over 0.50 up to and incl. 1.0	K12, K14, K18, K20, K22, K25, K27
	Over 1.0	K18, K20, K22, K25, K27
Note ^{a)} K35 and K45 may be applied according to the agreement between the purchaser and the manufacturer.		

Annex B (normative)

Nominal thickness, coating mass symbol and standard size for corrugated sheet

B.1 Scope

This Annex specifies the nominal thickness, the coating mass symbol and the standard size applicable to corrugated sheet.

B.2 Applicable nominal thickness and coating mass symbol

The nominal thickness and coating mass symbol applicable to corrugated sheet shall be as given in table B.1.

Table B.1 Applicable nominal thickness and coating mass symbol (using cold-rolled base metal)

Applicable nominal thickness mm	Coating mass symbol ^{a)}
0.20 or over to and excl. 0.27	K06, K08, K10, K12
0.27 or over up to and incl. 0.50	K08, K10, K12, K14, K18, K20, K22, K25, K27
Over 0.50 up to and incl. 1.0	K12, K14, K18, K20, K22, K25, K27
Note ^{a)} K35 and K45 may be applied according to the agreement between the purchaser and the manufacturer.	

B.3 Standard size

B.3.1 Standard nominal thickness

The standard nominal thickness of corrugated sheet shall be as given in table B.2.

Table B.2 Standard nominal thickness

Standard nominal thickness									Unit : mm
0.20	0.25	0.27	0.30	0.35	0.40	0.50	0.60	0.80	1.0

B.3.2 Standard width and standard length of corrugated sheet before corrugation

The standard width and standard length of corrugated sheet before corrugation shall be as given in table B.3.

Table B.3 Standard width and standard length

Standard width before corrugation	Standard length							Unit : mm
762	1 829	2 134	2 438	2 743	3 048	3 353	3 658	
914	1 829	2 134	2 438	2 743	3 048	3 353	3 658	
1 000	2 000							

Annex C (normative)

Off-line coating mass determination of hot-dip zinc-aluminium-magnesium alloy-coated steel sheet and strip by fluorescent X-ray method

C.1 Scope

This Annex specifies the test method for determining the coating mass of test pieces sampled from hot-dip zinc-aluminium-magnesium alloy-coated steel sheet and strip, and corrugated sheet before corrugation using a fluorescent X-ray test apparatus.

C.2 Principle of measurement

The intensity of fluorescent X-rays emitted from the coating of the test piece, when excited fluorescent X-rays is irradiated to the specimen, is measured, and the coating mass of the test piece is determined by comparison of this intensity to that of a specimen whose coating mass is known.

C.3 Apparatus

The apparatus shall be as specified in clause 5 of **JIS K 0119**.

C.4 Fluorescent X-ray to be measured

The fluorescent X-ray to be measured shall be the primary wave of ZnK α (wavelength 14.35 nm).

C.5 Test piece

C.5.1 Size of test piece

The size of a test piece shall be such that it can be installed in the sample room of the fluorescent X-ray test apparatus in which the area of primary X-ray irradiation on the test piece is controlled to be a minimum size of 314 mm².

C.5.2 Sampling position and number of test piece

The test piece shall be taken from the sample obtained in **13.2.1**, one at each of the three points shown in figure C.1, or any points close to them.

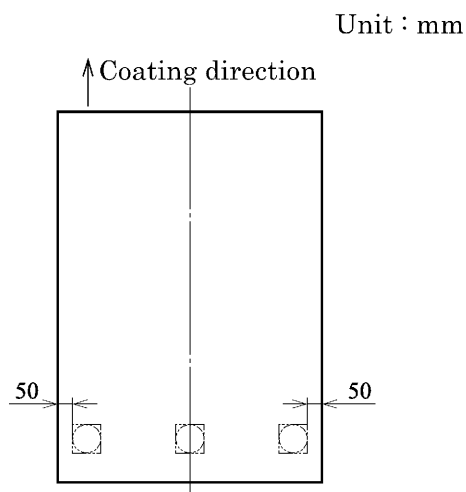

Figure C.1 Sampling positions of test pieces

C.6 Preparation and calibration of working curve

C.6.1 Preparation of working curve

Preparation of working curve shall be as follows. As an alternative to sampling the test pieces for determining the coating mass of X-ray measurement test pieces, the coating mass of an X-ray measurement test piece used in **c)** may be determined according to **5.2** of **JIS H 0401**, for preparation of working curve, in which case, the area of the X-ray measurement test piece shall be 1 200 mm² or greater.

- a) For preparation of a working curve, sample two sets of test pieces: one as X-ray measurement test pieces (hereafter referred to as “test piece A”), and another for determining the coating mass of the X-ray measurement test pieces (hereafter referred to as “test piece B”). Both sets of test pieces shall be taken from a steel sheet or strip of the same type of coating as the measured target. Take a single, or two adjacent, test piece(s) A, of such a size that they can fit within the sample room of the test apparatus. Further, take two test pieces B, one on each side of test piece(s) A, such that they are 1 200 mm² or greater in size.
- b) Decide on which surface of test pieces A to irradiate with the excited X-ray. Measure the coating mass of the decided surface of test pieces B, according to the method in **5.2** of **JIS H 0401**. In this case, apply lacquer on the face of the test pieces which is not the measured surface, and then dry, or apply a wide tape on it, for preventing elution of the coating layer. Obtain the average of the coating mass of two test pieces B, and take this value as the coating mass on the excited X-ray-irradiated face of test pieces A.
- c) Mount test piece A on the test apparatus, and irradiate excited X-ray on test piece A under the conditions given in **C.7 a)** to measure the intensity of the fluorescent X-ray.
- d) Using at least three sets of test piece A and test piece B with different coating mass,

create a working curve based on the relation between the fluorescent X-ray intensity and coating mass.

NOTE : The working curves have been prepared corresponding to the controlled concentration of zinc.

C.6.2 Calibration of working curve

Set the test piece for calibration on the apparatus, measure periodically ¹⁾ the fluorescent X-ray intensity or coating mass conversion value, and calibrate the working curve.

Note ¹⁾ This calibration should be performed, e.g. every 8 h or every day.

C.7 Procedure

The following procedure shall be performed :

- a) Install on the apparatus the test piece of the coating mass symbol of the minimum coating mass to be measured and set the conditions of the apparatus such that the relative standard deviation ²⁾ after 10 consecutive measurements is within 1 %, and the coating mass can be determined to the nearest 0.1 g/m². When the X-ray intensity is measured by counting, and the measured count is 10 000 or more, repetitive measurement is not necessary.

Note ²⁾ The standard deviation of the measurements (absolute value of square root of variance), divided by the average value (see **JIS K 0211**).

When measuring a coating mass smaller than that of the nominal coating mass symbol used in setting the conditions, confirm that the above conditions are satisfied by using a test piece of the relevant coating mass symbol. If the above conditions are not satisfied, re-setting of the conditions shall be performed.

- b) Set the test piece in the sample room correctly.
- c) Irradiate the X-ray to the test piece under the set conditions and measure the fluorescent X-ray intensity.
- d) Using the working curve, convert the fluorescent X-ray intensity to a coating mass (one surface, g/m²) per square metre.
- e) Repeat the above **b)** to **d)** on the rear surface of the test piece to determine the coating mass, and take the total coating mass of the front and rear surfaces of the test piece as the coating mass (both surfaces, g/m²) of this test piece.

C.8 Checks on apparatus

Adequate checks shall be made on the apparatus. For checking, the items given in clause 15 of **JIS K 0119** shall be examined, and also, normality of the coating mass measurements of the apparatus shall be confirmed by comparing them to the measured results obtained in 5.2 of **JIS H 0401**.

Annex D (normative)

On-line coating mass determination of hot-dip zinc-aluminium-magnesium alloy-coated steel strips by fluorescent X-ray method

D.1 Scope

This Annex specifies the test method for determining the coating mass of hot-dip zinc-aluminium-magnesium alloy-coated steel strips by means of a fluorescent X-ray apparatus installed on the production line.

Warning : Proper safety measures shall be taken in performing measurement and maintenance of facility according to this test method. Thorough safety control should be in place especially regarding possible exposure to radiation, among other things.

NOTE : The laws and regulations related to the installation and handling of the apparatus used in this test method are : Industrial Safety and Health Act, Ordinance on Prevention of Ionizing Radiation Hazards and so on.

D.2 Principle of measurement

The coil is irradiated by excited X-ray (including γ ray), and the intensity of fluorescent X-ray radiated from the coating is measured. This X-ray intensity from the coil is compared with that from another sample whose coating mass is known, and the coating mass of the coil is determined.

D.3 Apparatus

The apparatus shall be composed of an X-ray generating section, a spectroscopy, light scanning and counting sections and apparatus controlling and data processing sections and shall be in accordance with the following. The apparatus shall be installed in a place where there is no variation of temperature or humidity that can significantly affect the measurements.

D.3.1 X-ray generating section

The X-ray generating section shall be capable of irradiating the position of a coil specified in **D.6.3** with excited X-ray (including γ ray) directly.

D.3.2 Spectroscopy, light scanning and counting sections

The spectroscopy, light scanning and counting sections shall have a function to measure the intensity of fluorescent X-ray generated at the measuring point specified in **D.6.3**.

D.3.3 Apparatus controlling and data processing sections

The apparatus controlling and data processing sections shall be capable of control-

ling the X-ray generating section and spectroscopy, light scanning and counting sections by irradiating the position specified in **D.6.3** with excited X-ray (including γ ray) and measuring the intensity of the resultant emission of fluorescent X-ray and shall be capable of keeping interrelated records of their irradiating points and the measured results.

D.4 Fluorescent X-ray to be measured

The fluorescent X-ray to be measured shall be the primary ray of $ZnK\alpha$ (wavelength 14.35 nm). However, X-ray of other wavelengths may be applied at the same time, for purposes such as the calibration of distance between the measuring surface and the apparatus.

D.5 Preparation and calibration of working curve

D.5.1 Preparation of working curve

Preparation of working curve shall be as follows. As an alternative to sampling the test pieces for determining the coating mass of X-ray measurement test pieces, the coating mass of the X-ray measurement test piece used in **c)** may be determined according to **5.2** of **JIS H 0401**, for preparation of working curve. In this case, the X-ray measurement test piece shall be sampled to have an area of at least 1 200 mm².

- a) For preparation of a working curve, sample two sets of test pieces : one as X-ray measurement test pieces (hereafter referred to as “test piece A”), and another for determining the coating mass of the X-ray measurement test pieces (hereafter referred to as “test piece B”). Both sets of test pieces shall be taken from a steel sheet or coil of the same type of coating as the measured target. Take one, or two adjacent to each other, test piece(s) A, such that they are of a sufficient size to receive the X-ray irradiation from the apparatus when the apparatus is fixed. Further, take two test pieces B, one on each side of test piece(s) A, such that they are at least 1 200 mm² in size.
- b) Decide on which surface of test pieces A to irradiate with the excited X-ray (including γ ray). Measure the coating mass of the decided surface of test pieces B, according to the method in **5.2** of **JIS H 0401**. In this case, apply lacquer on the face of the test pieces which is not the measured surface, and then dry, or apply a wide tape on it, for preventing elution of the coating layer. Obtain the average of the coating mass of two test pieces B, and take this value as the coating mass on the excited X-ray-irradiated (including γ ray) face of test pieces A.
- c) Mount test pieces A on the test apparatus, and irradiate with excited X-ray (including γ ray) on test pieces A under the conditions given in **D.6.4 a)** to measure the intensity of the fluorescent X-ray.
- d) Using at least three sets of test piece A and test piece B with different coating mass, create a working curve based on the relation between the fluorescent X-ray intensity and coating mass.

NOTE : The working curves have been prepared corresponding to the con-

trolled concentration of zinc.

D.5.2 Calibration of working curve

The calibration of working curve shall be as given in C.6.2.

D.6 Measurement method

D.6.1 Measurement surface

The surface of the coil on which the coating mass is to be measured shall be free from contamination and adhesion of metal powder which may significantly influence the measurements. The distance and inclination between the measurement surface and the apparatus shall be equivalent to the distance and inclination in measurement of the X-ray measurement test piece. When there is such a deviation in distance or inclination between the coil and the apparatus that it influences the measurements, the influence shall be compensated.

D.6.2 Measuring mode

The measuring mode of the coating mass can be either that in which the apparatus is fixed on the specified position of the coil in the width direction (hereafter referred to as “fixed point measurement mode”), or that in which the apparatus is moved at a constant speed in the width direction (hereafter referred to as “scanning mode”), while irradiating with X-ray for measurement of coating mass. Which of the measuring modes to apply for measurement shall be a matter of decision of the manufacturer.

D.6.3 Measuring point of coating mass

The measuring point of coating mass shall be as shown in a) of figure D.1 for fixed point measurement mode, and shall be as shown in b) of figure D.1 for scanning mode. In the fixed point measurement mode, the apparatus shall be moved to three points in which the outer edges of the X-ray beam are 50^{+30}_0 mm from the edges of the coil (ends in width direction) and the centre of the X-ray beam is ± 15 mm from the centre of the coil width, and the coating mass shall be measured at each point. In the scanning mode, the apparatus shall be moved at a constant speed in the width direction of the coil, and the coating mass shall be measured at each of the three measuring areas (A) shown in b) of figure D.1. In this case, side edge measuring area shows the outer edges of X-ray beam and the measuring area at the coil width centre shows the centre of X-ray beam.

The coating mass shall be measured on both the front and rear surfaces. The measuring points of width direction shall be the same for both the front and rear surfaces of the coil, and measuring points of longitudinal directions of the front and rear surfaces of the coil shall be as close as possible.

Unit : mm

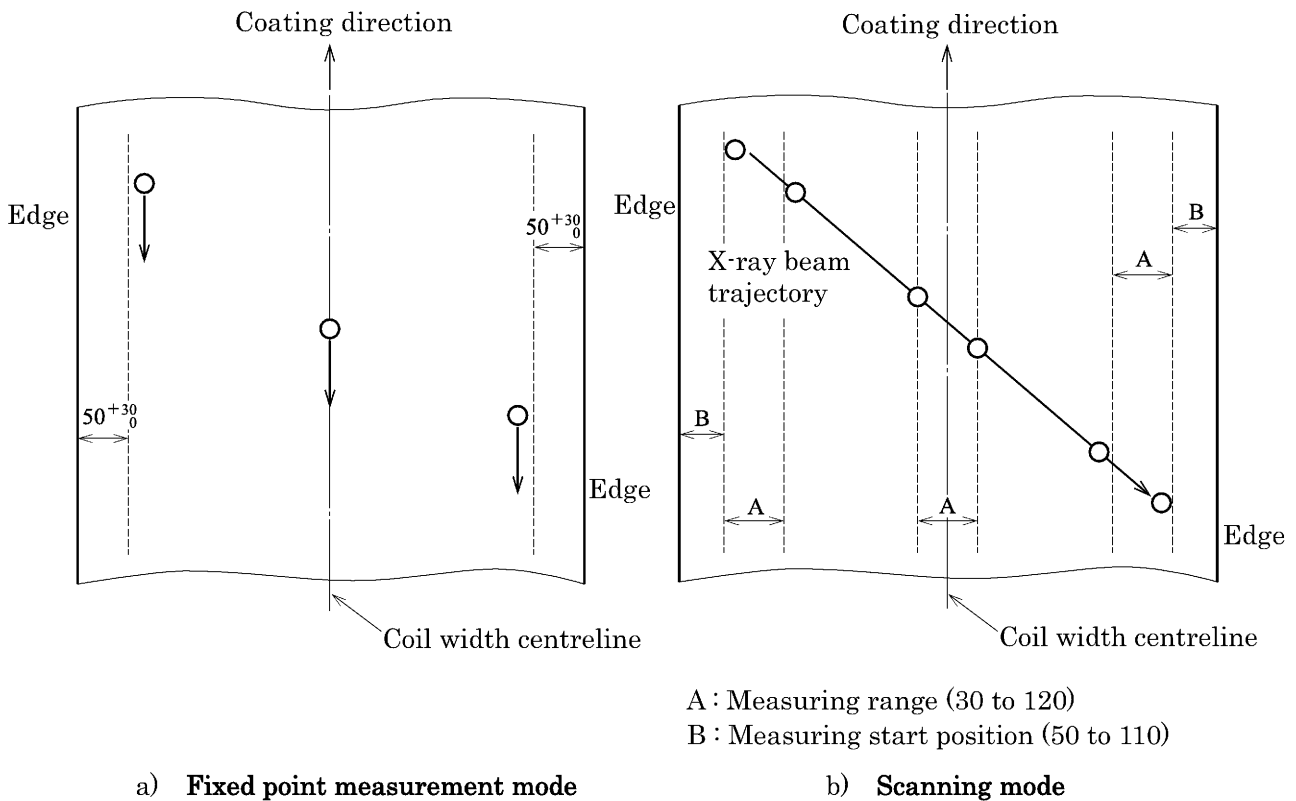

Figure D.1 Measuring point of coating mass

D.6.4 Measurement

The measurement shall be as follows.

- a) The measuring time for one point shall be 4 s or less. Mount on the apparatus the test piece of the coating mass symbol of the minimum coating mass to be measured on the production line on which the apparatus is installed and set the conditions of the apparatus such that the relative standard deviation ¹⁾ obtained when 10 consecutive measurements of the specified duration are performed is within 1 %, and the coating mass can be determined to the nearest 0.1 g/m². When the X-ray intensity is measured by counting, and the measured count is 10 000 or more, repetitive measurement is not necessary.

Note ¹⁾ The standard deviation of the measurements (absolute value of square root of variance), divided by the average value (see **JIS K 0211**).

When measuring a coating mass smaller than that of the nominal coating mass symbol used in setting the conditions, confirm that the above conditions are satisfied by using a test piece of the relevant coating mass symbol. If the above conditions are not satisfied, re-setting of the conditions shall be performed.

- b) Irradiate the coil with X-ray under the set conditions and measure the fluorescent X-ray intensity.

- c) Using the working curve, convert the fluorescent X-ray intensity to a coating mass (one surface, g/m²) per square metre.

Further, when the coil area changes after measurement of the coating mass due to performance of skin-pass, etc., correct the coating mass with the area changing rate.

- d) Sum up the front and rear surface coating mass, and take this value as the coating mass at one point of coil (both sides, g/m²).

D.6.5 Measured value of coating mass

Using the values of the coating mass measured at three points of optional one pass²⁾, obtain the average coating mass and minimum coating mass. The measurement may be performed over more than one pass, in which case, the average coating mass shall be the average of all the measured coating mass values, and the minimum coating mass shall be the minimum of all the measured coating mass values.

Note ²⁾ One pass means the measurement performed over one-directional movement of the X-ray generating section from one optional point at one edge of the coil to the other edge.

D.7 Checks on apparatus

The checks on the apparatus shall be performed appropriately. The items to be checked shall be in accordance with clause 15 of **JIS K 0119** and the following :

- a) The temperature and humidity of the place where the apparatus is installed do not influence the measured results.
- b) The distance and angle between the apparatus and the coil at the time of measurement are constant.
- c) The distance and angle between the test piece and the apparatus at the time of calibration are equivalent to those at the time of measurement of coil.
- d) During scanning mode, the apparatus moves at a constant speed.
- e) The apparatus measures the coating mass of coil under the specified conditions.
- f) The apparatus is not so contaminated that the measured results may be influenced.
- g) The results measured by the apparatus are normal, based on comparison of results of the coating mass obtained by this method and the results obtained by other methods (Annex C or 5.2 of **JIS H 0401**).

Errata for JIS (English edition) are printed in *Standardization and Quality Control*, published monthly by the Japanese Standards Association, and also provided to subscribers of JIS (English edition) in *Monthly Information*.

Errata will be provided upon request, please contact:

Standards Publishing Department, Japanese Standards Association

4-1-24, Akasaka, Minato-ku, Tokyo, 107-8440 JAPAN

TEL. 03-3583-8002 FAX. 03-3583-0462

PROTECTED BY COPYRIGHT